



## ROLLER SHUTTER PROFILE



Foam-filled Slats For Roller Shutter

ULEPANDA

# ▼ 6 Product Features

- Sun-shading
- Sound insulation
- Wind-proof and dust-proof
- Ventilation and dimming
- Cold proof
- Privacy and security



## ▼ 39mm\*0.22mm Aluminum Slat

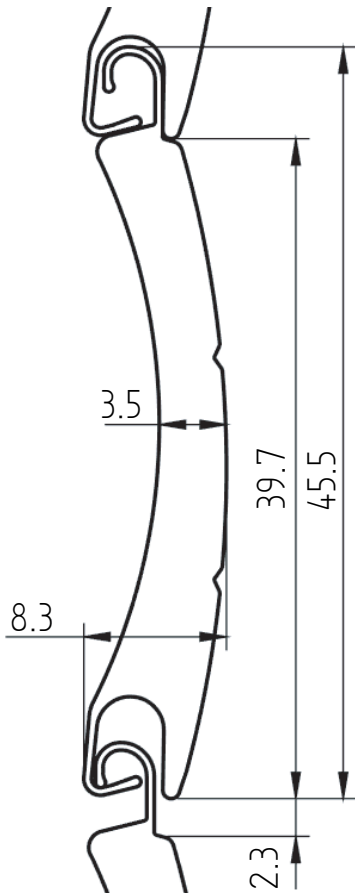

### Technical Specifications

Size	39mm
Nominal Thickness	8.3mm
Plate Thickness	0.22mm
Weight	83g/m, 2.12kg/m <sup>2</sup>
Lighting Hole Size	1×12mm
Pu Density	60-65kg/m <sup>3</sup>
Maximum Shutter Width	≤2.4m
Maximum Shutter Height	≤3.0m
Slats Per Meter	25.6

### Packing Data

Length	5.8m-6.5m
Slats Per Package	60 Pcs



## Diameters of winding

Height (mm)	Diameter		
	φ40	φ50	φ60
600	105	105	110
800	105	115	120
1000	120	120	120
1200	130	130	135
1400	130	140	135
1600	140	140	145
1800	140	155	150
2000	155	155	155
2200	155	170	160
2400	165	170	165
2600	165	170	170
2800	180	180	180
3000	180	180	180
3200	180	195	190
3400	195	195	195
3600	195	195	195
3800	195	205	205
4000	210	205	210

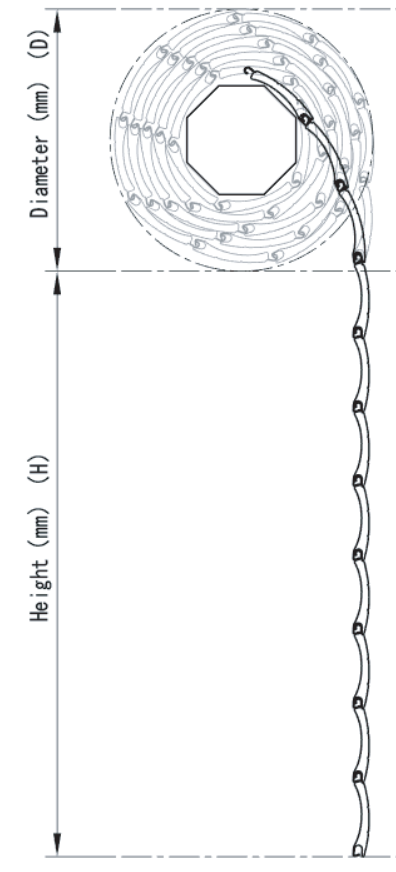

# ▼ 40mm\*0.30mm Aluminum Slat

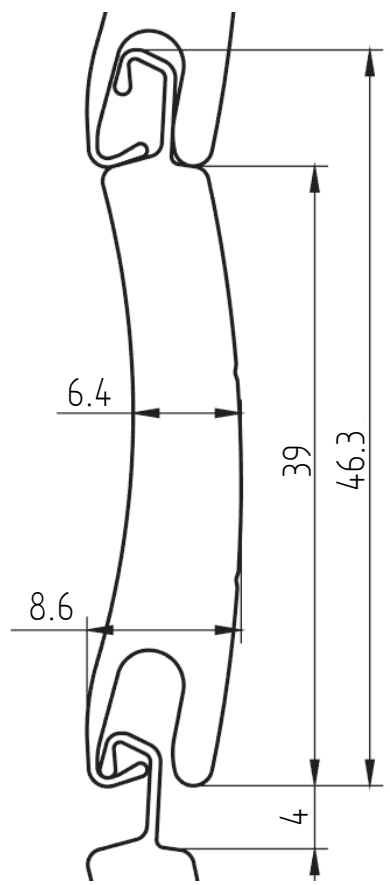

## Technical Specifications

Size	40mm
Nominal Thickness	8.6mm
Plate Thickness	0.3mm
Weight	120g/m, 3kg/m <sup>2</sup>
Lighting Hole Size	1×12mm
Pu Density	60-65kg/m <sup>3</sup>
Maximum Shutter Width	≤2.4m
Maximum Shutter Height	≤3.0m
Slats Per Meter	25

## Packing Data

Length	5.8m-6.5m
Slats Per Package	50 Pcs



## Diameters of winding

Height (mm)	Diameter		
	φ40	φ50	φ60
600	105	120	125
800	125	140	135
1000	140	140	140
1200	145	160	155
1400	160	160	160
1600	165	170	165
1800	170	180	175
2000	180	185	180
2200	180	195	190
2400	195	195	195
2600	200	200	195
2800	200	215	210
3000	215	215	210
3200	215	220	215
3400	215	230	225
3600	230	230	230
3800	235	235	230
4000	235	250	240

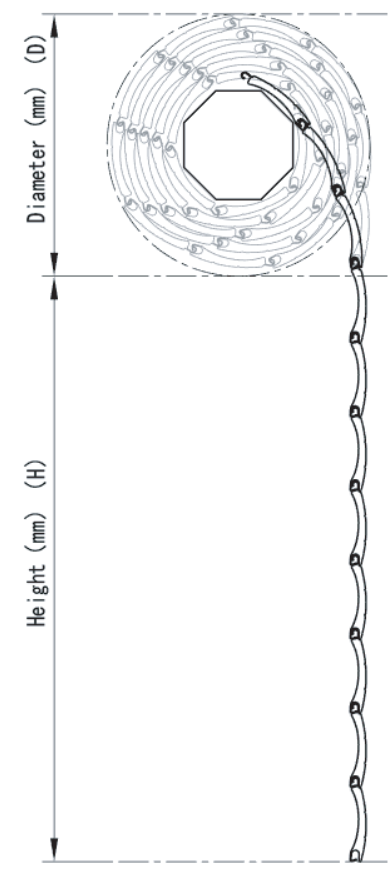

## ▼ 45mm\*0.25mm Aluminum Slat

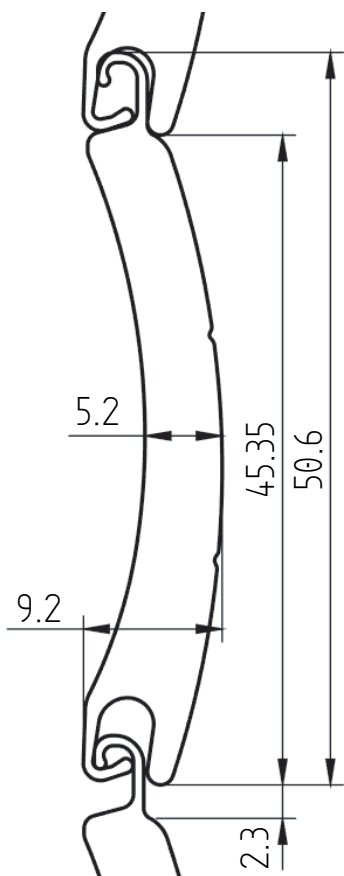

### Technical Specifications

Size	45mm
Nominal Thickness	9.2mm
Plate Thickness	0.25mm
Weight	97g/m, 2.2kg/m <sup>2</sup>
Lighting Hole Size	1×12mm
Pu Density	60-65kg/m <sup>3</sup>
Maximum Shutter Width	≤3.0m
Maximum Shutter Height	≤3.0m
Slats Per Meter	22.2

### Packing Data

Length	5.8m-6.5m
Slats Per Package	56 Pcs



## Diameters of winding

Height (mm)	Diameter		
	φ40	φ50	φ60
600	105	110	115
800	120	125	125
1000	135	135	130
1200	135	140	140
1400	150	150	145
1600	150	155	155
1800	160	160	160
2000	165	170	170
2200	170	170	175
2400	180	175	175
2600	180	185	190
2800	195	190	190
3000	195	190	190
3200	195	200	205
3400	210	205	205
3600	210	215	210
3800	210	215	220
4000	225	220	220

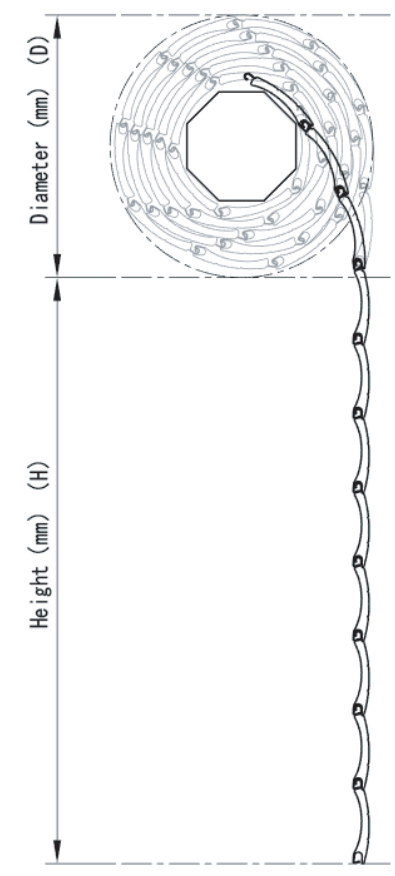



## ▼ 39mm/40mm/45mm Performance and application

Rolling shutter slats are made of aluminum and filled with a very dense ecologic foam for added strength and superior insulation value. The standard 39mm/40mm/45mm slats are our most commonly used slats for rolling shutter windows.

- Roll formed aluminum slat
- Powder coated finish for longevity
- Five standard colors
- Slats interlock together to prevent separation under load
- Used for rolling shutter on windows, kitchen cabinets, trucks and so on.



## ▼ 55mm\*0.30mm Aluminum Slat

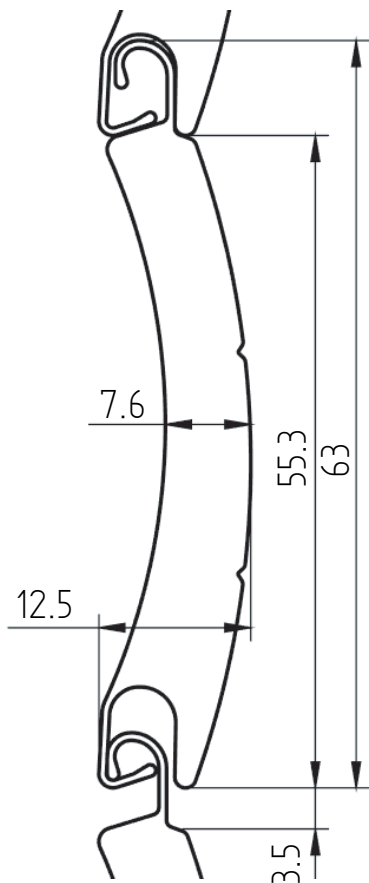

### Technical Specifications

Size	55mm
Nominal Thickness	12.5mm
Plate Thickness	0.3mm
Weight	165g/m, 3.0kg/m <sup>2</sup>
Lighting Hole Size	1.5×17mm
Pu Density	60-65kg/m <sup>3</sup>
Maximum Shutter Width	≤3.3m
Maximum Shutter Height	≤3.5m
Slats Per Meter	18

### Packing Data

Length	5.8m-6.5m
Slats Per Package	30 Pcs



## Diameters of winding

Height (mm)	Diameter	
	φ60	φ70
600	140	145
800	145	155
1000	165	175
1200	170	180
1400	185	185
1600	190	200
1800	200	200
2000	210	210
2200	210	225
2400	220	225
2600	230	230
2800	230	245
3000	235	245
3200	250	245
3400	250	265
3600	255	270
3800	270	270
4000	275	280

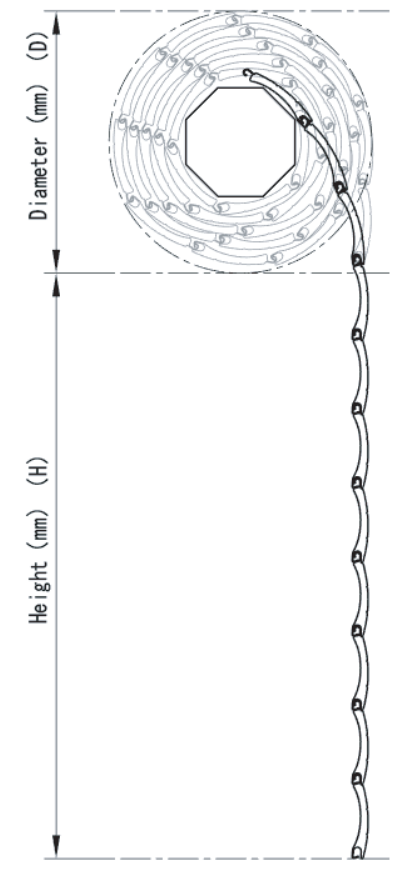

## ▼ 55mm Performance and application

The 55mm slat is used for wider openings and free expanses between posts or columns.

- 5 standard colors
- Roll-formed aluminum slat
- Powder coated finish for longevity
- Injected with an ecologic foam for insulation and rigidity
- Slats interlock together to prevent separation under load.
- Used for rolling shutters on warehouse doors, parking garages and residential doors



## ▼ 77mm\*0.44mm Aluminum Slat

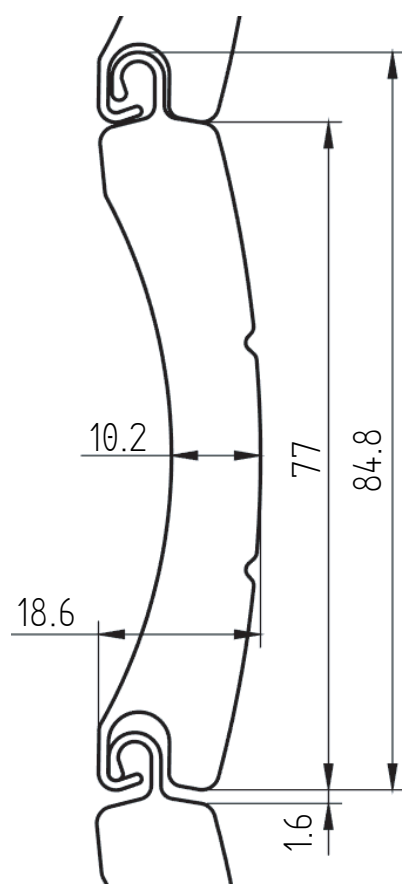

### Technical Specifications

Size	77mm
Nominal Thickness	18.6mm
Plate Thickness	0.44mm
Weight	310g/m, 4.0kg/m <sup>2</sup>
Lighting Hole Size	-
Pu Density	60-65kg/m <sup>3</sup>
Maximum Shutter Width	≤5.0m
Maximum Shutter Height	≤4.0m
Slats Per Meter	13

### Packing Data

Length	3m-7.5m
Slats Per Package	10 Pcs



## Diameters of winding

Height (mm)	Diameter	
	$\phi 70$	$\phi 89$
1000	180	200
1200	200	200
1400	210	215
1600	220	230
1800	235	230
2000	235	245
2200	235	250
2400	255	255
2600	265	275
2800	265	275
3000	270	285
3200	285	285
3400	300	305
3600	300	305
3800	300	310
4000	315	320

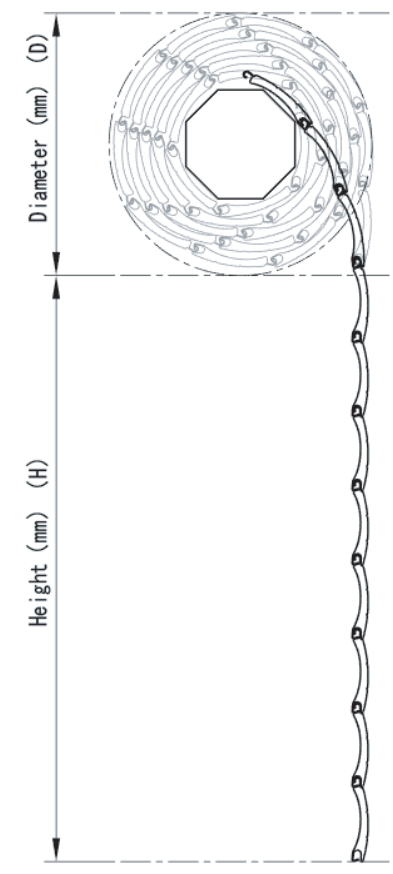

# ▼ 77mm\*0.58mm PVC Coating Steel Slats

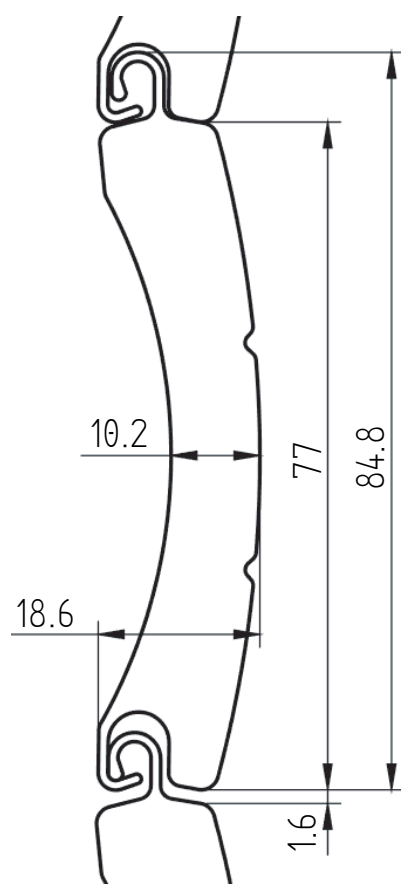

## Technical Specifications

Size	77mm
Nominal Thickness	18.6mm
Plate Thickness	0.58mm
Weight	840g/m, 10.92kg/m <sup>2</sup>
Lighting Hole Size	-
Pu Density	60-65kg/m <sup>3</sup>
Maximum Shutter Width	≤6.0m
Maximum Shutter Height	≤4.2m
Slats Per Meter	13

## Packing Data

Length	3m-7.5m
Slats Per Package	6 Pcs



## Diameters of winding

Height (mm)	Diameter	
	φ70	φ89
1000	180	200
1200	200	200
1400	210	215
1600	220	230
1800	235	230
2000	235	245
2200	235	250
2400	255	255
2600	265	275
2800	265	275
3000	270	285
3200	285	285
3400	300	305
3600	300	305
3800	300	310
4000	315	320

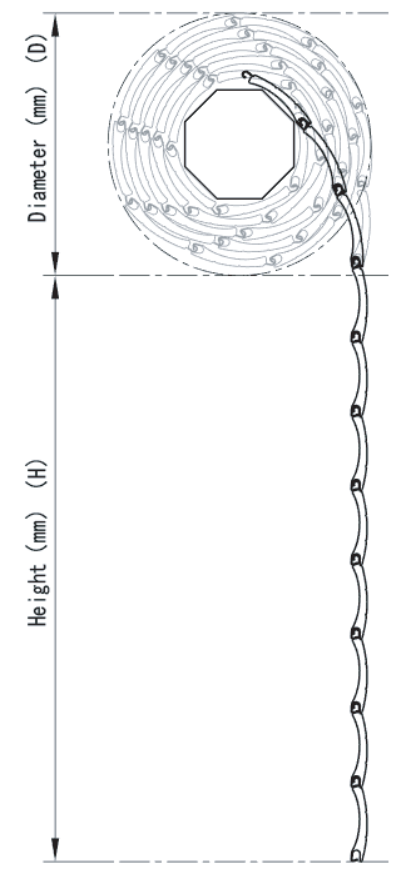



## ▼ 77mm Performance and application

The 77mm slat is a kind of security profile with polyurethane foam insulation, and it has the highest level of rolling shutter protection.

- Designed with the strength and durability
- Ideal for larger shutter systems and high security needs
- Ideal for storefronts that face risk of break-ins
- Provide a high quality PVC coating on steel slats



# ▼ Durable

PVC lamination process is used on the surface of the rolling shutter door sheet. PVC lamination process is a special treatment of PVC film by high temperature on the metal plate, with wear-resistant, scratch-resistant, strong adhesion and other unique properties, to achieve a combination of beauty and durability in one of the uses of value.

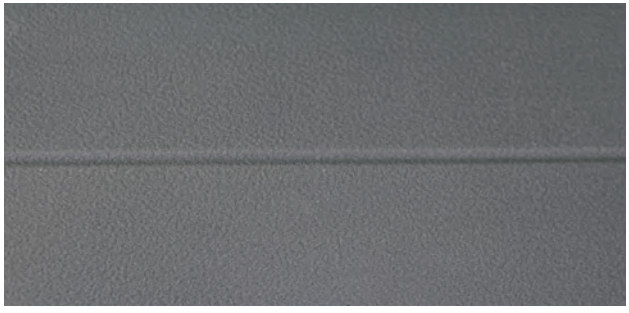
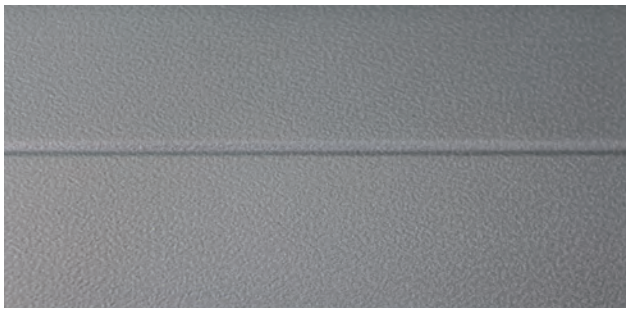
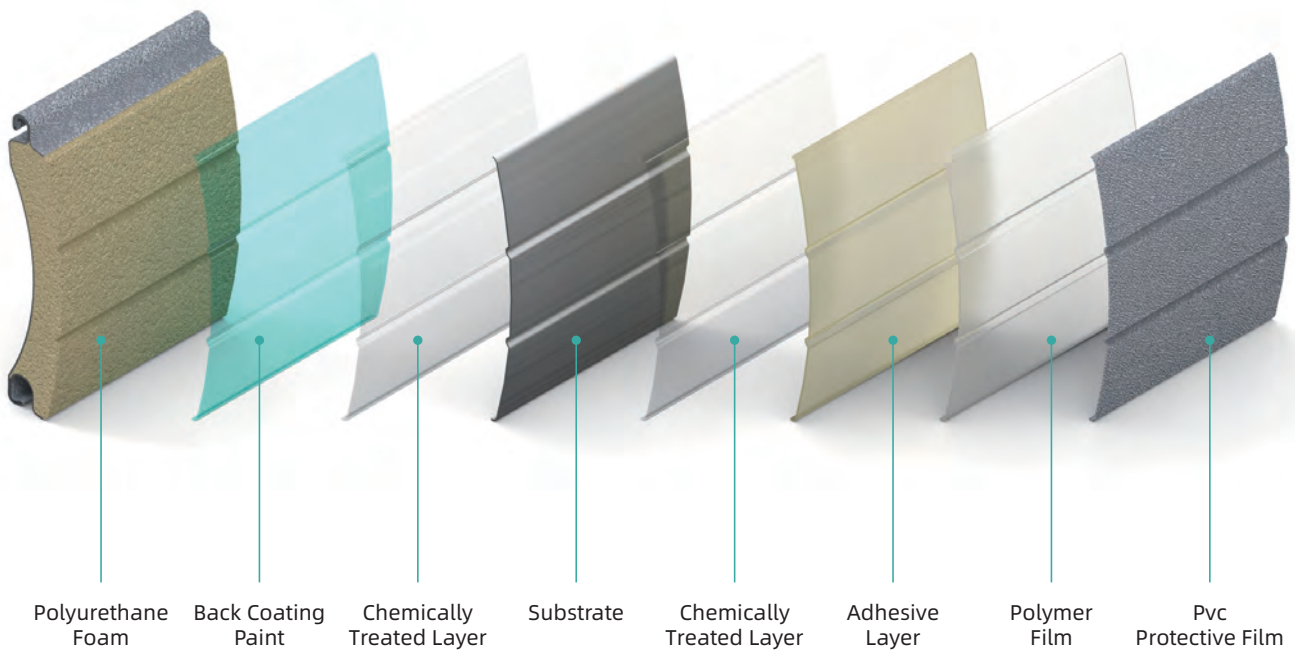

## ▼ RICH COLORS

For all the visible surfaces of our products made of aluminum, we offer five common color combinations or customized by RAL colors. The color scheme will always match your building space perfectly.

### BASIC COLOR

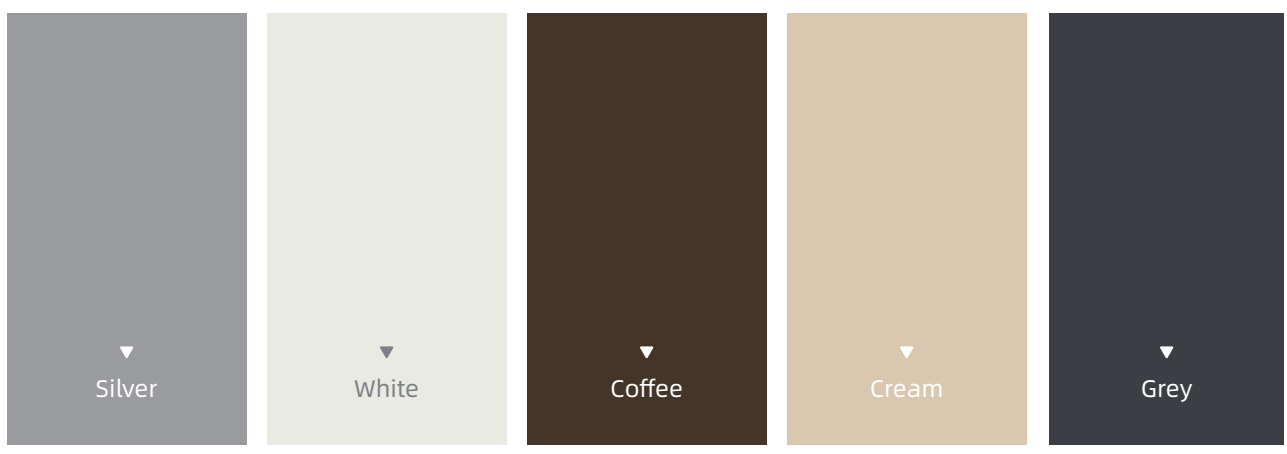

### PERSONALIZED COLOR

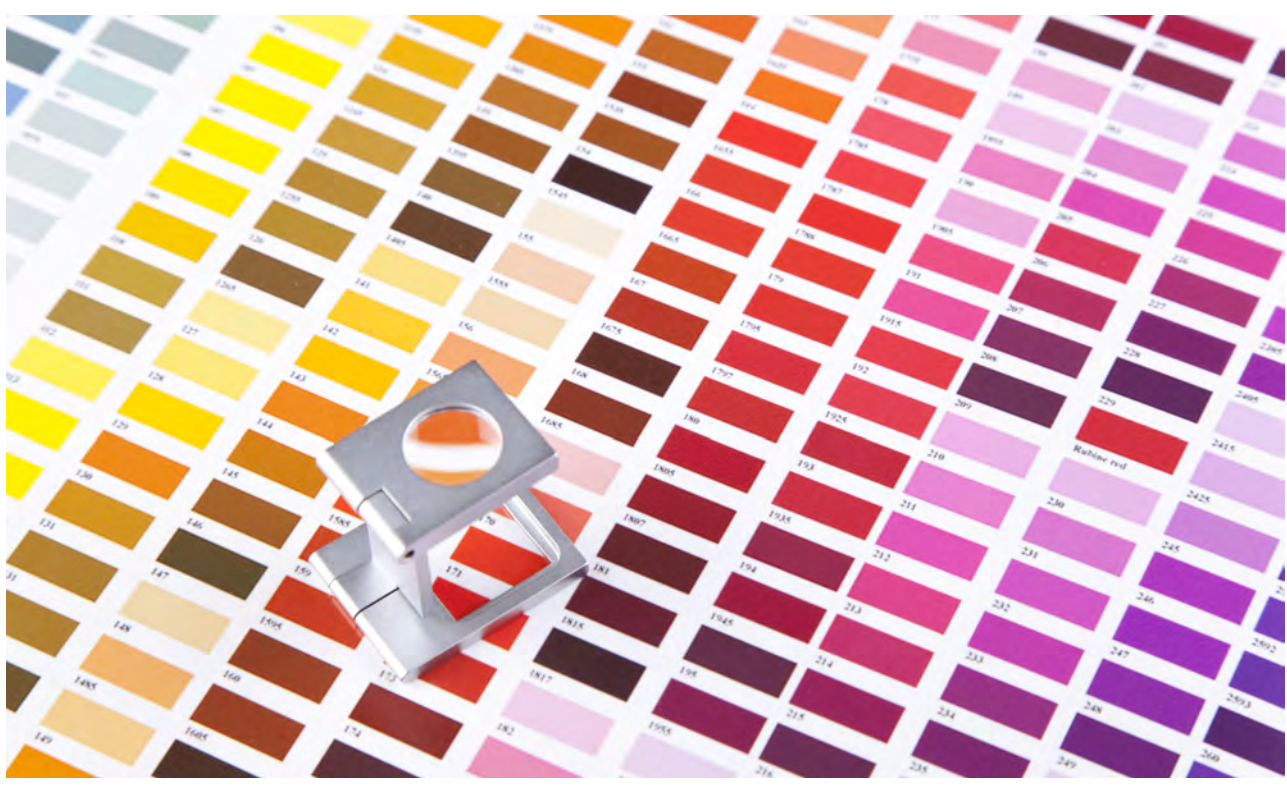

## ▼ QUALITY ASSURANCE



- Five years warranty for the condition under regular use and maintenance and without human damage;
- Provide five years the quality assurance of aluminum alloy materials do not fade.

### EXCELLENT CRAFTSMANSHIP

Imported from Italy production line, each production shift, each batch of materials has a self-inspection sample to ensure 100% quality inspection and comply with the EU standards. Each product will be the same.

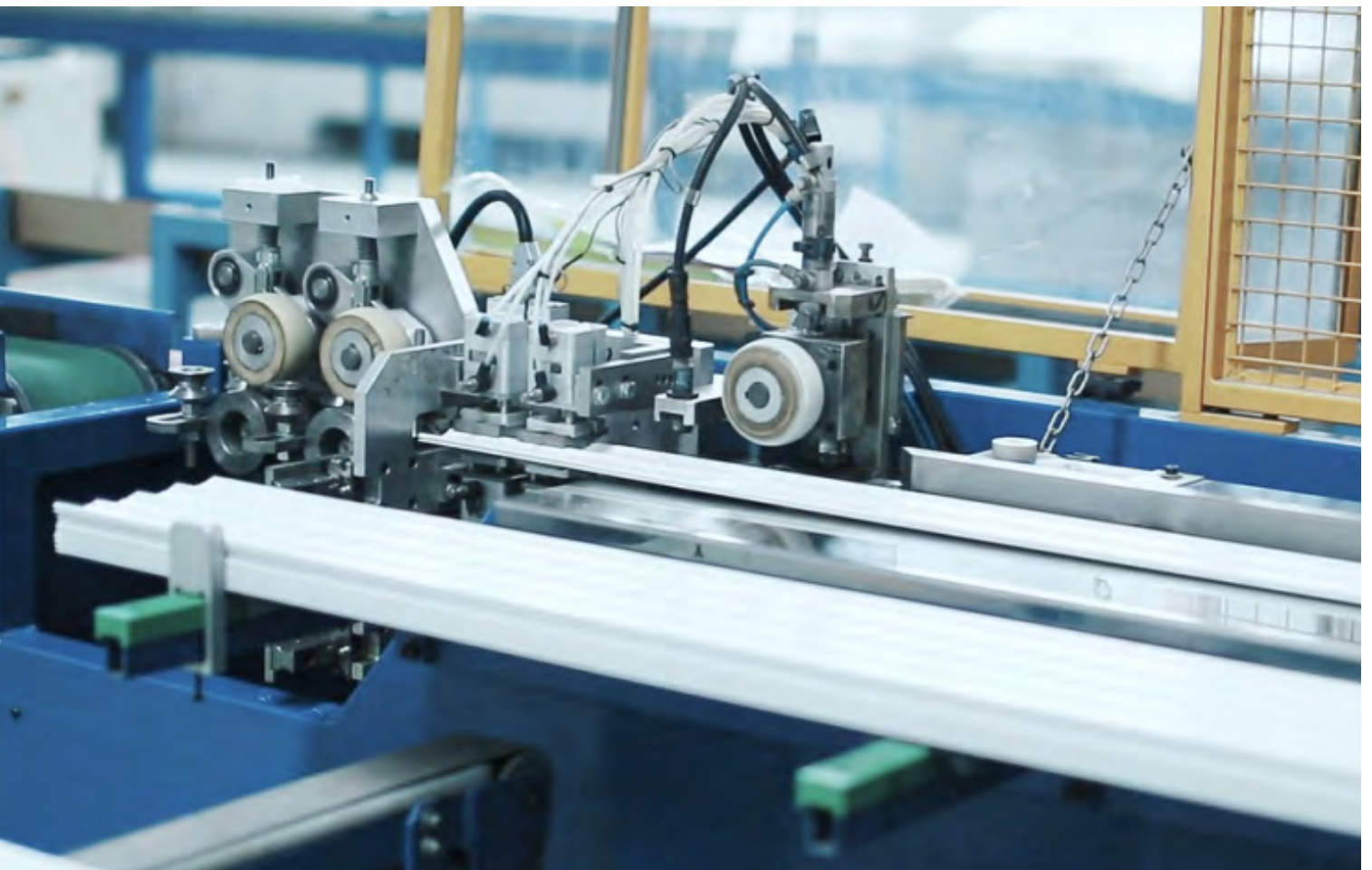

# ULEPANDA

ULE PANDA

Craft by Nanjing Jinxing Yu  
Energy Saving Technology Co., Ltd

---

Address: 6 Liyuan Rd, Pukou District, Nanjing, Jiangsu, China, 211806

Email: [Info.ulepanda@gmail.com](mailto:Info.ulepanda@gmail.com)

[www.ulepanda.com](http://www.ulepanda.com)

